

QSKE 100 Extended Carriage

Call 800-321-7800 or visit us online at www.nookindustries.com to configure and order your QSKE 100 Extended Carriage today!

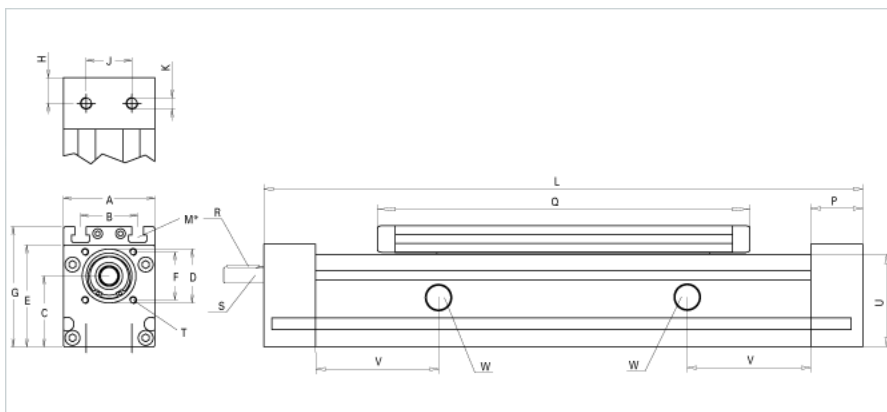
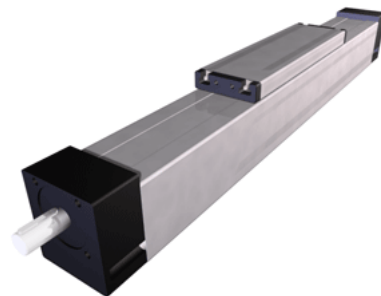

Details	
Size	100
Screw Options	32x5/32x10/32x32
Screw Type	Ball Screw
Dimensions	
Basic Length L [mm]	510
A [mm]	101
B [mm]	66
C [mm]	75.5
D [mm]	68
E [mm]	112.5
F [mm]	60
G [mm]	130
H [mm]	28.5
J [mm]	50
K	M10
N	M10
P [mm]	57
Q [mm]	383
Shaft R Key [mm]	6x6x40
Shaft S Diameter x Length [mm]	22h6x45
T	M8
U [mm]	101
Forces and Torques	
Fx [N] 10000 km	4000
Fy [N] 10000 km	2910
Fz [N] 10000 km	7360
Mx [Nm] 10000 km	101
My [Nm] 10000 km	597
Mz [Nm] 10000 km	532
Fx [N] 5000 km	5000
Fy [N] 5000 km	4082
Fz [N] 5000 km	10300
Mx [Nm] 5000 km	142
My [Nm] 5000 km	838
Mz [Nm] 5000 km	745
Geometrical moments of inertia of aluminum profile	
Elastic modulus [N/mm ²]	70000
Ix [mm ⁴]	4300000
Iy [mm ⁴]	4880000
Weight	
Weight Per 100 mm [kg]	1.3
Basic Weight [kg]	14.8