

ELZA 80S Extended Carriage

Call 800-321-7800 or visit us online at www.nookindustries.com to configure and order your ELZA 80S Extended Carriage today!

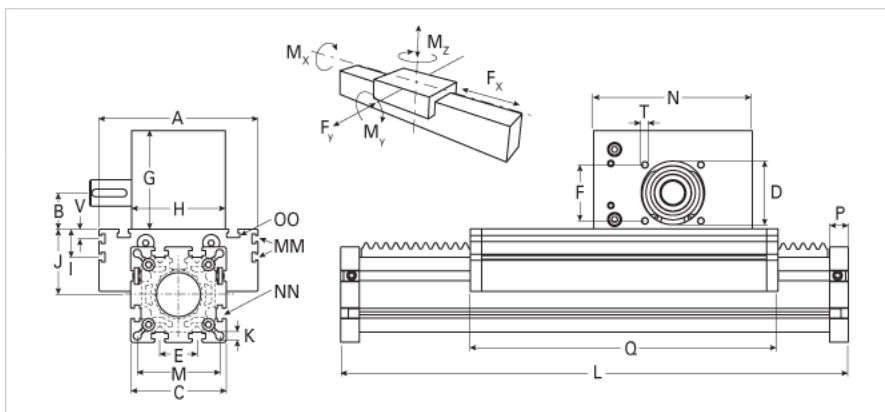
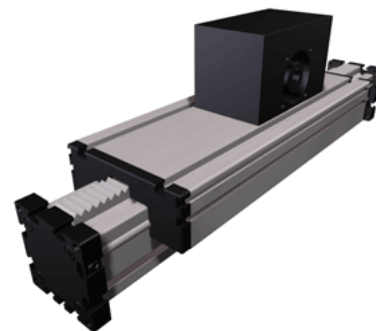

Details	
Size	80S
Dimensions	
Basic Length L [mm]	435
A [mm]	190
B [mm]	39.0
C [mm]	102
D [mm]	68
E [mm]	40
F [mm]	60
G [mm]	105
H [mm]	100
I [mm]	30
J [mm]	71
K [mm]	8.5
M [mm]	88
MM	M6
N [mm]	170
NN	M10
OO	M8
P [mm]	20
Q [mm]	389
T	M8
X [mm]	12.5
Speed	
Speed Maximum [m/s]	3
Forces and Torques	
Fx dynamic [N]	1800
Fy dynamic [N]	3600
Fz dynamic [N]	1800
Mx dynamic [Nm]	140
My dynamic [Nm]	230
Mz dynamic [Nm]	220
Fx static [N]	2200
Fy static [N]	4600
Fz static [N]	3000
Mx static [Nm]	170
My static [Nm]	270
Mz static [Nm]	300
Geometrical moments of inertia of aluminum profile	
Elastic modulus [N/mm ²]	70000
Ix [mm ⁴]	1899000
Iy [mm ⁴]	1897000
Weight	
Additional Weight per 100 mm [kg]	1.19
Basic Weight [kg]	12.9