

## ELT 60S WAC

Call 800-321-7800 or visit us online at [www.nookindustries.com](http://www.nookindustries.com) to configure and order your ELT 60S WAC today!

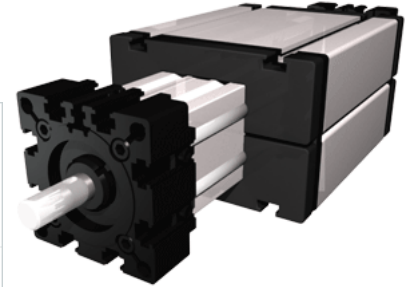
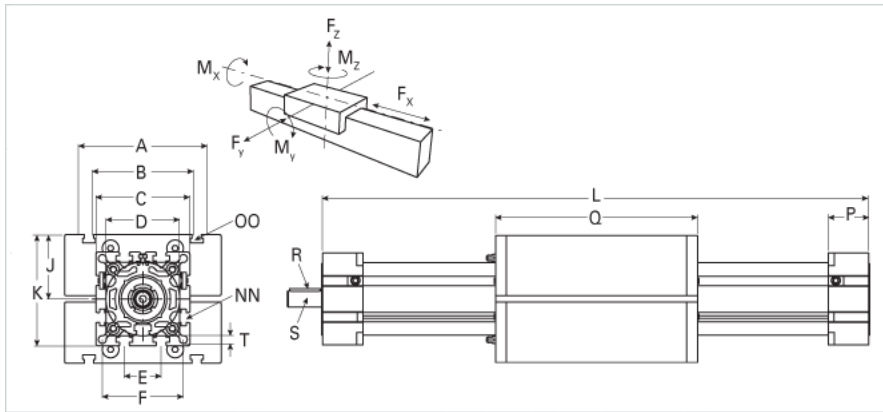

Details	
Size	60S
Screw Options	24x5/24x10
Screw Type	Trapezoidal
Dimensions	
Basic Length L [mm]	290
A [mm]	170
B [mm]	108
C [mm]	82
D [mm]	62x1
E [mm]	30
F [mm]	69
G [mm]	-
H [mm]	-
J [mm]	49
K [mm]	90
MM	-
NN	M8
OO	M8
P [mm]	35
Q [mm]	214
R [mm]	5x5x28
S Diameter x Length [mm]	14x35
T-Diameter [mm]	8.5
Forces and Torques	
No-load torque [Nm]	0.6
Fx dynamic [N]	2000
Fy dynamic [N]	3100
Fz dynamic [N]	1600
Mx dynamic [Nm]	65
My dynamic [Nm]	140
Mz dynamic [Nm]	170
Fx static [N]	2500
Fy static [N]	4100
Fz static [N]	2160
Mx static [Nm]	88
My static [Nm]	190
Mz static [Nm]	230
Geometrical moments of inertia of aluminum profile	
Elastic modulus [N/mm <sup>2</sup> ]	70000
Ix [mm <sup>4</sup> ]	679000
Iy [mm <sup>4</sup> ]	697000
Weight	
Additional Weight per 100 mm [kg]	0.89
Basic Weight [kg]	5.1