

ELT 100 WAC

Call 800-321-7800 or visit us online at www.nookindustries.com to configure and order your ELT 100 WAC today!

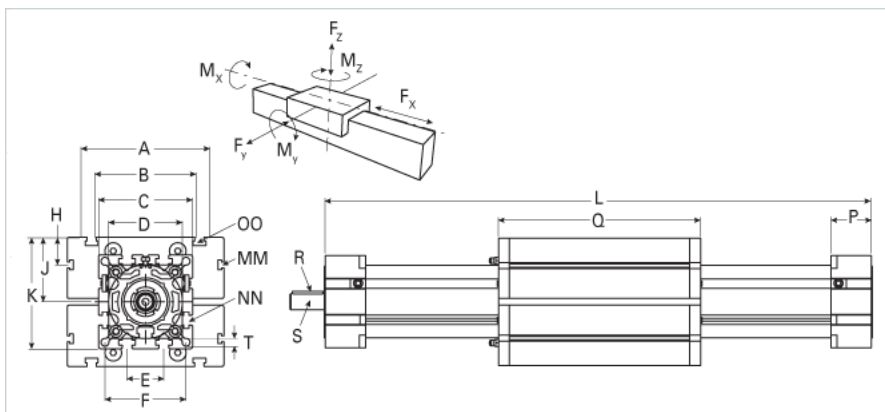
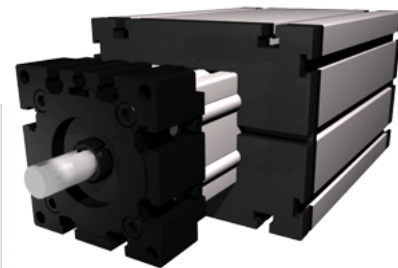

| Details | |
|--|-------------|
| Size | 100 |
| Screw Options | 32x6/32x12 |
| Screw Type | Trapezoidal |
| Dimensions | |
| Basic Length L [mm] | 426 |
| A [mm] | 230 |
| B [mm] | 155 |
| C [mm] | 130 |
| D [mm] | 110x1 |
| E [mm] | 50 |
| F [mm] | 112 |
| G [mm] | - |
| H [mm] | 29 |
| J [mm] | 89 |
| K [mm] | 154 |
| MM | M10 |
| NN | M10 |
| OO | M10 |
| P [mm] | 55 |
| Q [mm] | 316 |
| R [mm] | 6x6x40 |
| S Diameter x Length [mm] | 22x45 |
| T-Diameter [mm] | 10.5 |
| Forces and Torques | |
| No-load torque [Nm] | 1.1 |
| Fx dynamic [N] | 8000 |
| Fy dynamic [N] | 6500 |
| Fz dynamic [N] | 2200 |
| Mx dynamic [Nm] | 230 |
| My dynamic [Nm] | 270 |
| Mz dynamic [Nm] | 500 |
| Fx static [N] | 10000 |
| Fy static [N] | 8000 |
| Fz static [N] | 3600 |
| Mx static [Nm] | 300 |
| My static [Nm] | 400 |
| Mz static [Nm] | 750 |
| Geometrical moments of inertia of aluminum profile | |
| Elastic modulus [N/mm ²] | 70000 |
| Ix [mm ⁴] | 4440000 |
| Iy [mm ⁴] | 4480000 |
| Weight | |
| Additional Weight per 100 mm [kg] | 2.00 |
| Basic Weight [kg] | 19.0 |