

NH15TA Assembly

Call 800-321-7800 or visit us online at www.nookindustries.com to configure and order your NH15TA Assembly today!

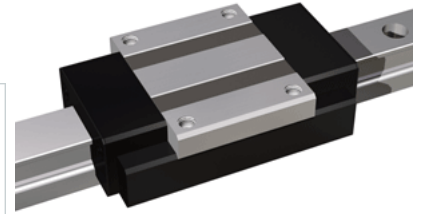
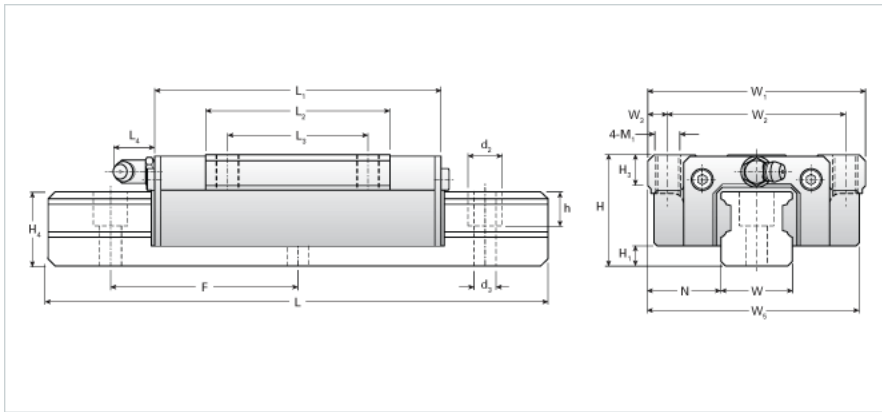

Dimensions	
H [mm]	24
H1 [mm]	4.6
N [mm]	16.0
Metric Profile Rail (Rail)Details	
Size [mm]	15
Type	Standard
(Rail)Dimensions	
d2 [mm]	7.5
d3 [mm]	4.5
h [mm]	7
H4 [mm]	17
F [mm]	60
W [mm]	15
Maximum Length [mm]	3000
(Rail)Weight	
Weights-Rail [kg/m]	1.7
Metric Runner Block, Heavy Load, High Speed, 4 Tapped Holes On Flange (Runner Block)Details	
Size [mm]	15
(Runner Block)Dimensions	
L1 [mm]	71
L2 [mm]	38.5
L3 [mm]	30
L4 [mm]	0
M1 x l	M5X7
H3 [mm]	7
W1 [mm]	47
W2 [mm]	38
W3 [mm]	4.5
W5 [mm]	46.5
(Runner Block)Forces and Torques	
Basic Load Ratings C [kN]	8.43
Basic Load Ratings C [lbf]	1895
Basic Load Ratings C0 [kN]	13.53
Basic Load Ratings C0 [lbf]	3041
Static Moment Ratings-Ma [kN-m]	0.07
Static Moment Ratings-Ma [lb-in]	608
Static Moment Ratings-Mb [kN-m]	0.07
Static Moment Ratings-Mb [lb-in]	608
Static Moment Ratings-Mc [kN-m]	0.13
Static Moment Ratings-Mc [lb-in]	1128
(Runner Block)Weight	
Weight-Block [kg]	0.2
(Runner Block)Grease Fitting	
Grease Fitting Part Number	NAS516-1A