

NH15ER

Call 800-321-7800 or visit us online at www.nookindustries.com to configure and order your NH15ER today!

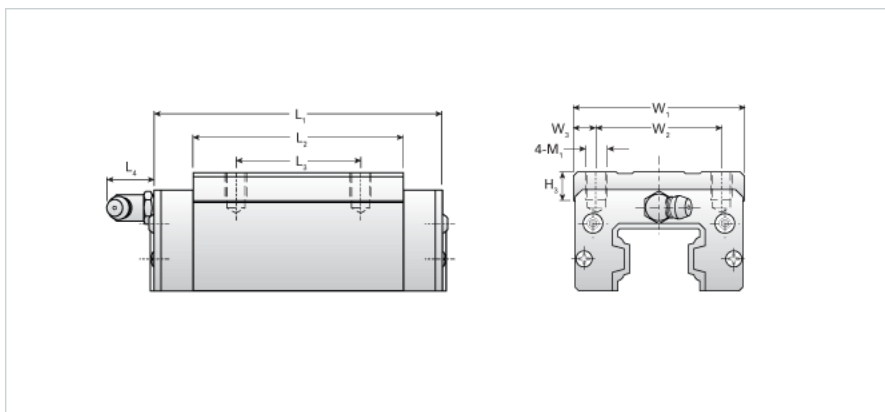

Details	
Size [mm]	15
Dimensions	
L1 [mm]	59
L2 [mm]	38.5
L3 [mm]	26
L4 [mm]	0
M1 x l	M4X5
H3 [mm]	6
W1 [mm]	34
W2 [mm]	26
W3 [mm]	4
Forces and Torques	
Basic Load Ratings C [kN]	8.82
Basic Load Ratings C [lbf]	1982
Basic Load Ratings C0 [kN]	17.02
Basic Load Ratings C0 [lbf]	3826
Static Moment Ratings-Ma [kN-m]	0.12
Static Moment Ratings-Ma [lb-in]	1036
Static Moment Ratings-Mb [kN-m]	0.12
Static Moment Ratings-Mb [lb-in]	1036
Static Moment Ratings-Mc [kN-m]	0.18
Static Moment Ratings-Mc [lb-in]	1523
Weight	
Weight-Block [kg]	0.20
Grease Fitting	
Grease Fitting Part Number	NAS516-1A