

ELFZ 100

Call 800-321-7800 or visit us online at www.nookindustries.com to configure and order your ELFZ 100 today!

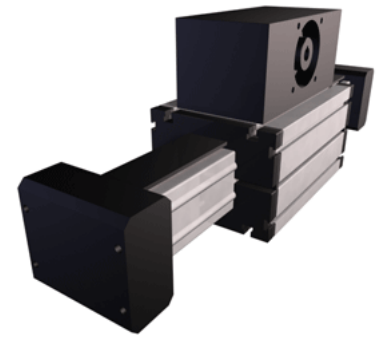
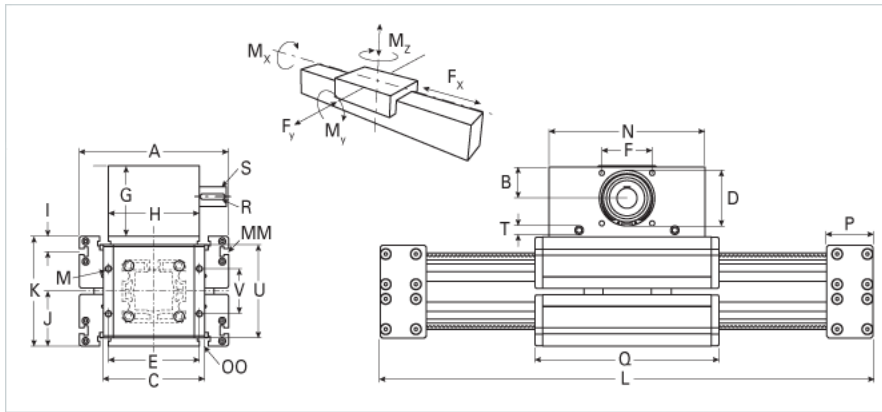

Details

Size	100
Belt	8M70
mm/Rev	152
Number of Teeth	38

Dimensions

Basic Length L [mm]	530
A [mm]	230
B [mm]	62
C [mm]	170
D [mm]	110
E [mm]	150
F [mm]	100
G [mm]	143
H [mm]	160
I [mm]	29
J [mm]	89
K [mm]	178
M	M10
MM	M10
N [mm]	310
OO [mm]	M10
P [mm]	77
Q [mm]	365
R [mm]	12x8x50
S [mm]	40x55
T	M10
U [mm]	150
V [mm]	80
Shaft Diameter and Length [mm]	40 x 55
Key	12x8x50

Speed

Speed Maximum [m/s]	4
---------------------	---

Forces and Torques

Drive Torque Maximum [Nm]	386
No-load torque [Nm]	2
Mz dynamic [Nm]	1000
Mz static [Nm]	1500
Fx dynamic [N]	7600
Fy dynamic [N]	13000
Fz dynamic [N]	4400
Mx dynamic [Nm]	460
My dynamic [Nm]	540
Fx static [N]	8700
Fy static [N]	16000
Fz static [N]	7200
Mx static [Nm]	600
My static [Nm]	800

Geometrical moments of inertia of aluminum profile

Elastic modulus [N/mm ²]	70000
Ix [mm ⁴]	4440000
Iy [mm ⁴]	4480000

Weight

Additional Weight per 100 mm [kg]	1.80
-----------------------------------	------

Basic Weight [kg]	69.0
Values for Calculating Inertias	
Pulley Material - Drive Pulley (x5)	Aluminum
Pulley Material - Idler Pulleys (x2)	Plastic
Pulley Diameter [mm]	96.77
Effective Pulley Width [mm]	160
Belt Weight [kg/m]	0.355
Standard Carriage Weight [kg]	20.10
No-load torque [Nm]	2.0
Friction Coefficient	0.01